

PACKAGE INFORMATION AND DIMENSIONS

Vertical Through-Hole Mount (Suffix V)

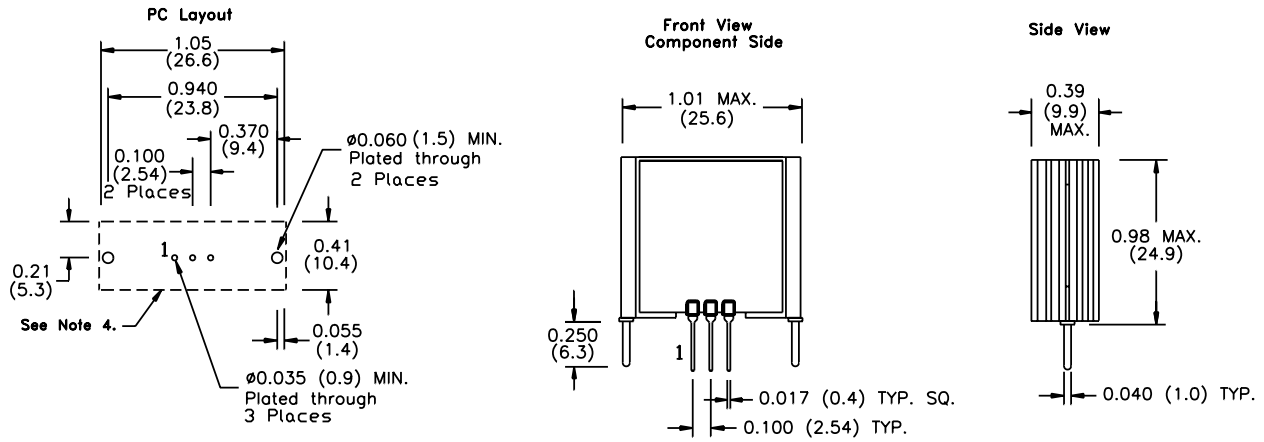

Notes: (Rev.A)

- 1: All dimensions are in inches (mm).
- 2: All tolerances for 2 place decimals are ± 0.030 (0.8mm).
- 3: All 3 place decimals are ± 0.010 (0.3mm).
- 4: Recommended mechanical keep out area.

PACKAGE INFORMATION AND DIMENSIONS

Horizontal Through-Hole Mount (Suffix H)

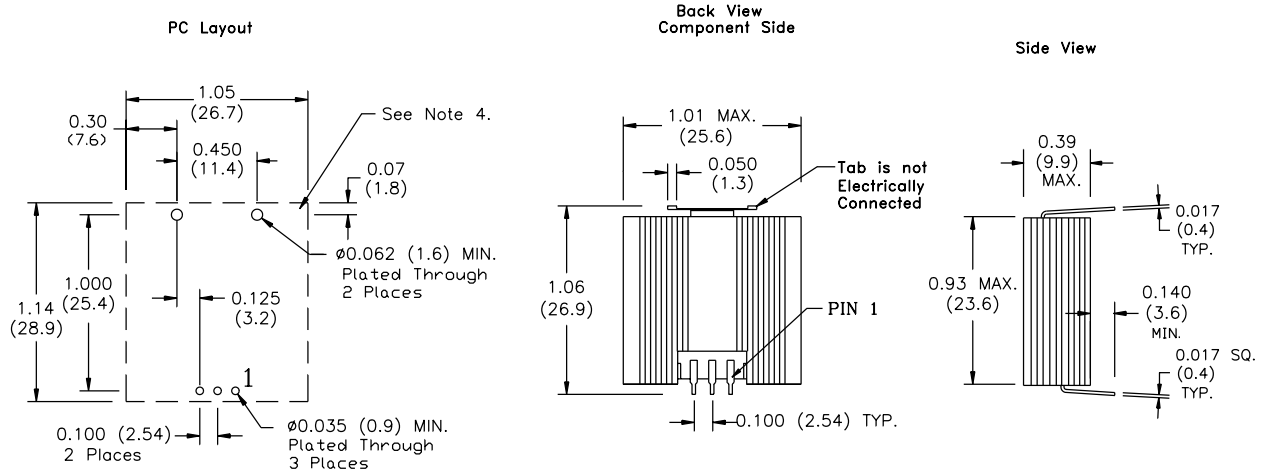

Horizontal Surface Mount Mount (Suffix S)

