

PACKAGE INFORMATION AND DIMENSIONS

Vertical Through-Hole Mount (Suffix N)

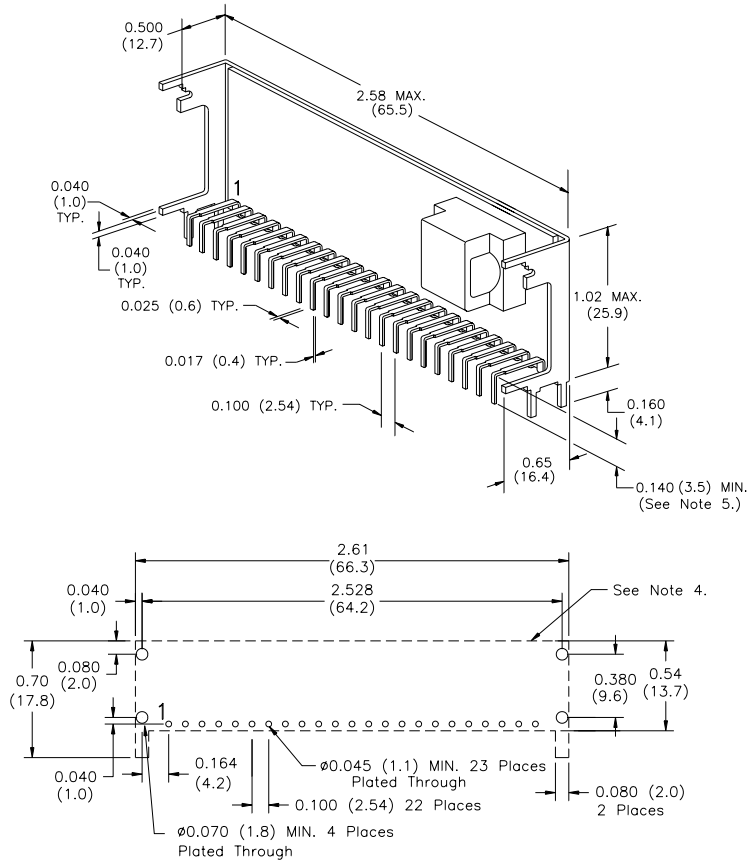

PC Layout

Notes: (Rev. E)

- 1: All dimensions are in inches (mm).
- 2: 2 place decimals are ± 0.030 (± 0.8 mm).
- 3: 3 place decimals are ± 0.010 (± 0.3 mm).
- 4: Recommended mechanical keep out area (dotted line).
- 5: Electrical pin length mounted on printed circuit board seating plane to pin end.

Power Trends proprietary package design.
All rights reserved. Patent pending.

PACKAGE INFORMATION AND DIMENSIONS

Horizontal Through-Hole Mount (Suffix A)

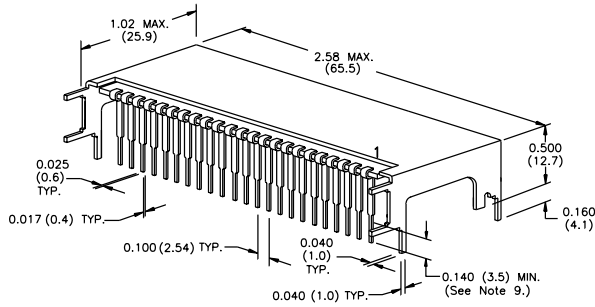

Horizontal Surface Mount (Suffix C)

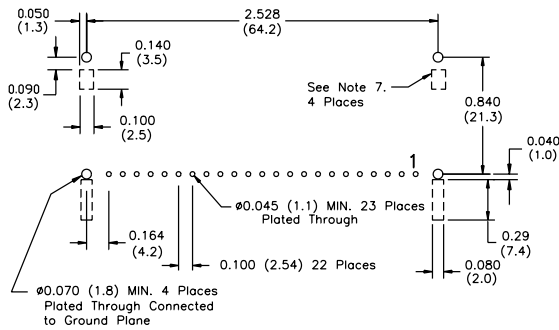
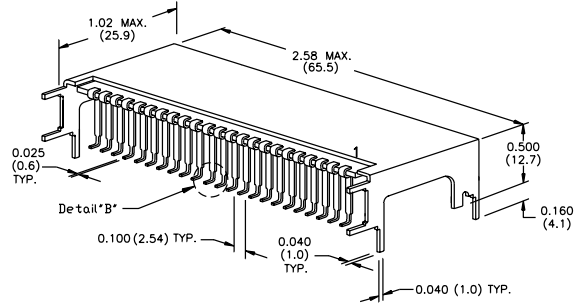

PC Layout

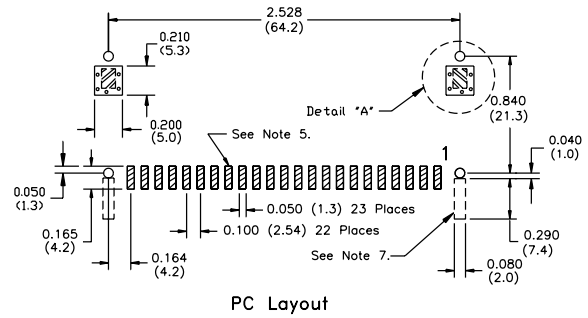

PC Layout

Notes: (Rev. F)

- 1: All dimensions are in inches (mm).
- 2: 2 place decimals are ± 0.030 ($\pm 0.8\text{mm}$).
- 3: 3 place decimals are ± 0.010 ($\pm 0.3\text{mm}$).
- 4: Vias are recommended to improve copper adhesion.
- 5: Power pin connections should utilize two or more vias per input, ground and output pin.
- 6: Solder mask openings to copper island for solder joints to mechanical pins.
- 7: Recommended mechanical keep out area (dotted lines).
- 8: Electrically connect case to ground plane.
- 9: Electrical pin length (Horizontal Thru Hole) mounted on printed circuit board seating plane to pin end.

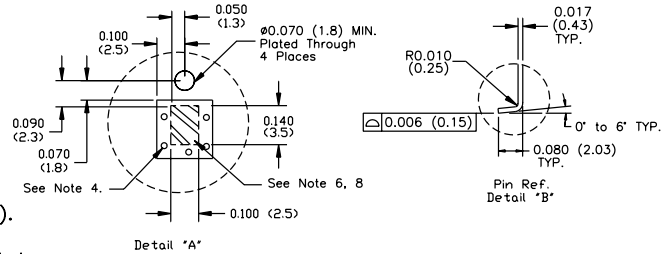

Power Trends proprietary package design.
All rights reserved. Patent pending.